

# SPRINKLE IRRIGATION SYSTEM

*Appropriate irrigation technology for smallholder farmers*



## SUPPLY CHAIN



## Guidelines for Installation and Operation



**IDE**

INTERNATIONAL DEVELOPMENT ENTERPRISES

IDE | Nepal P.O. Box 2674, Kathmandu  
Tel 01 552 0943

# CONTENTS

	<b>Section</b>	<b>Page No.</b>
1	Introduction	2
2	Terminology	3-6
3	Main features and application of sprinkler	7
4	Components of the sprinkler irrigation system	7-8
5	Sizes and technical parameters	8
6	Materials and parts	9-10
7	Installation and operation process	11
7.1	Water conveyance up to the field	11
7.2	Setting up the sprinkler sets and pipes on the field	12
7.3	Irrigating the field	12-13
7.4	Moving the sprinkler position	13
8	Maintenance and storage	15
8.1	Cleaning the line filter	15
8.2	Checking the pipelines	15
8.3	Storage	15
9	Where to purchase the technology	16

## 1. INTRODUCTION

Sprinkle irrigation is the method of irrigation by which water is sprayed on the land surface in the form of artificial rain. To create the precipitation, water under pressure is ejected through the nozzle of a device called a sprinkler. Sprinkle irrigation systems are available in various designs and irrigation capacities.

There are two basic categories of sprinkler heads – small and large. Compared to “large” sprinklers, “small” sprinklers have a relatively small radius of throw and can operate at low pressures and flow conditions. As the precipitation rate of “small” sprinklers is relatively light, the possibility of soil erosion is negligible. Thus, “small” sprinklers are useful when irrigating a small piece of uneven land with narrow terraces.

IDE/Nepal works only with sprinklers in the “small” category, which include the subcategories of “mini” and “micro” sprinklers. Usually, sprinklers with a flow rate of less than 150 liters per hour are called micro-sprinklers. Mini-sprinklers are those which have a flow rate between 150 - 300 liters per hour. In 2001, IDE/Nepal began promoting “small” sprinkle technology in the pre-assembled form which included a complete package of sprinklers, pipes and accessories. The sprinklers are now available in several areas of Nepal from multiple dealers.

These guidelines provide basic information about the pre-assembled mini- and micro-sprinklers, their installation process and applications. It is expected that these guidelines will be useful for lead farmers and field level technicians to understand sprinkler irrigation systems and enable them to assist farmers in correct installation and operation.

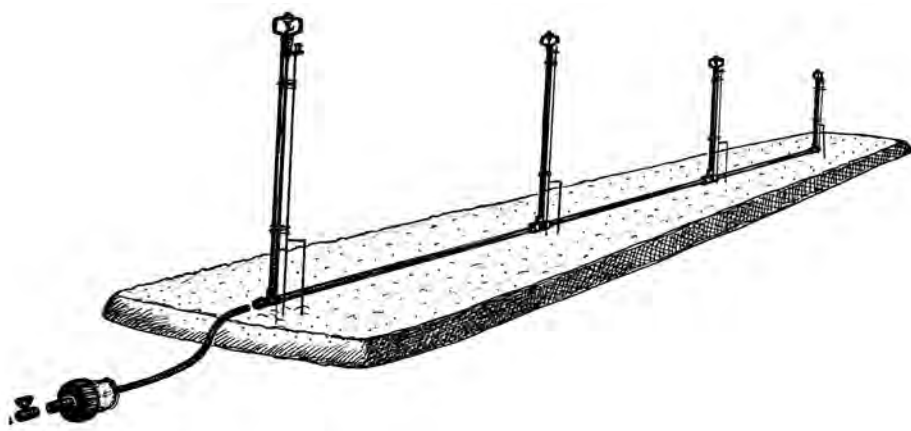

4 Microsprinkler heads in one bed

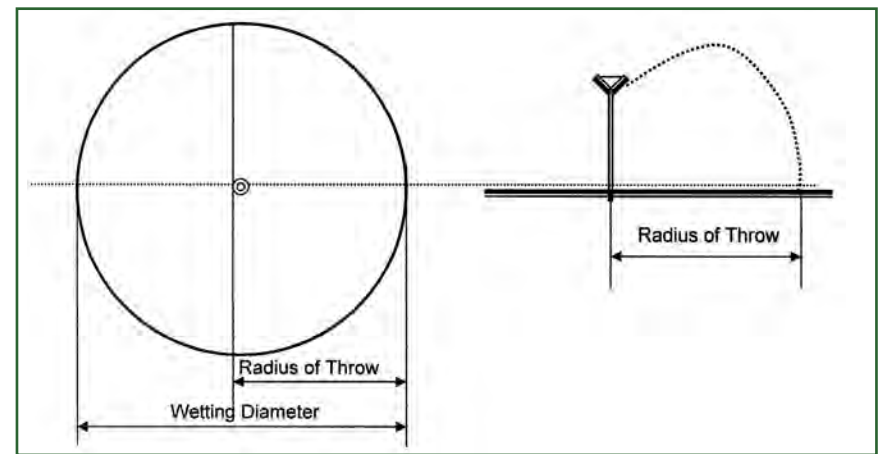

- **Uniformity of water application** This parameter, expressed as a percentage, measures how uniformly the water is falling on the ground. Ideally, an equal amount of water should fall on every point of the field. In reality, 70% and above is an acceptable water distribution uniformity.

## 2. TERMINOLOGY

- **Wetting circle** The circular area on the ground where water is projected from the sprinkler head. The diameter of the wetting circle is called the "wetting diameter."

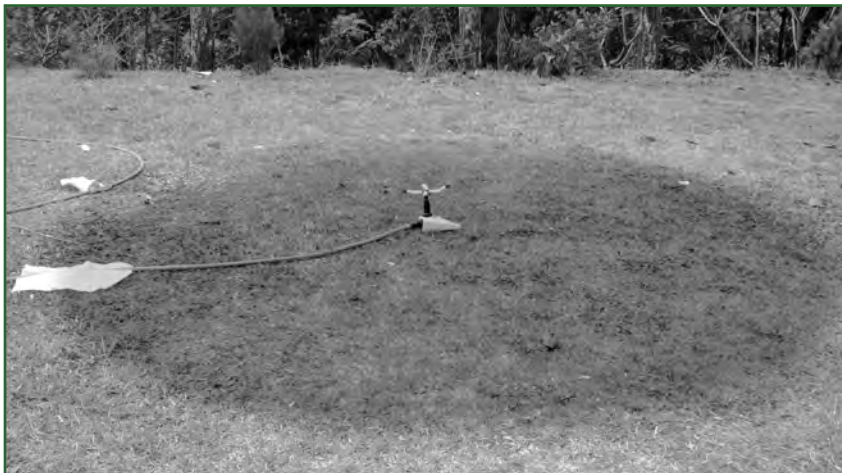

Wetting circle



- **Overlapping of the precipitation** The precipitation rate from individual sprinkler heads is not uniform throughout the wetting circle. To get a desirable water distribution uniformity two adjacent sprinklers should be spaced such that there is some overlap of the precipitation. As a general rule, the spacing between the sprinklers is kept between 50-60% of the "wetting diameter."

- **Radius of throw** The horizontal distance between the position of the sprinkler head and the farthest point of the precipitation. Usually, the precipitation rate decreases the further the point is from the sprinkler head.

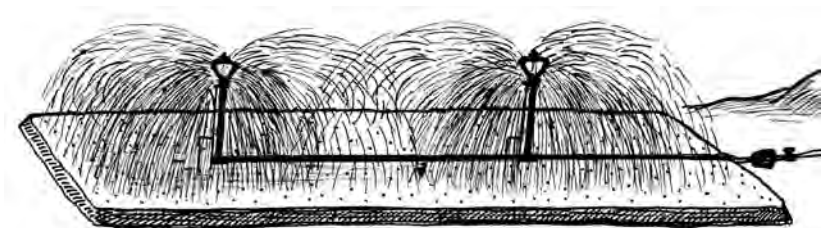

- **Water pressure** Simply put, pressure is the vertical height of the water column. Frictional losses along the pipelines are deducted to obtain the net residual pressure at the outlet point. Sprinklers are operated through the energy of water under pressure. Some common ways of obtaining water under pressure are use of gravity or by pumping. Pressure that is too high or too low is not desirable for the operation of sprinklers as it can affect watering application uniformity.

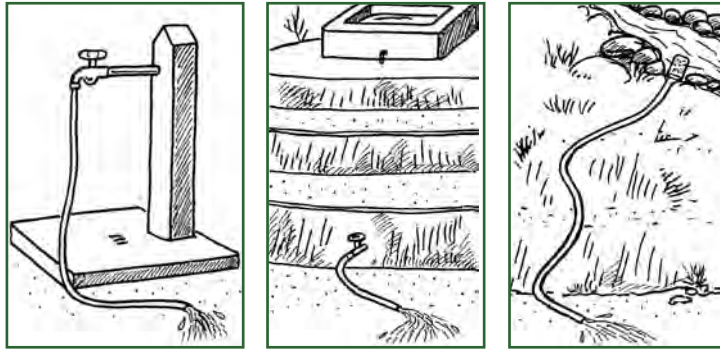

Gravity flow

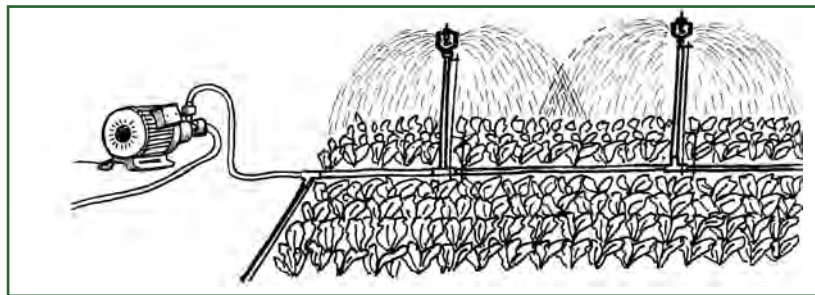

Electric pump

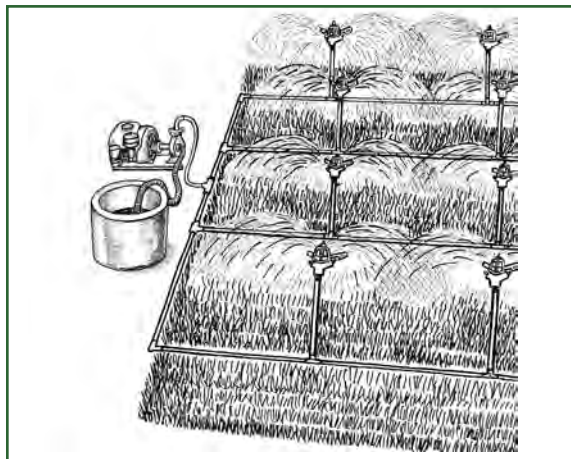

Diesel pump

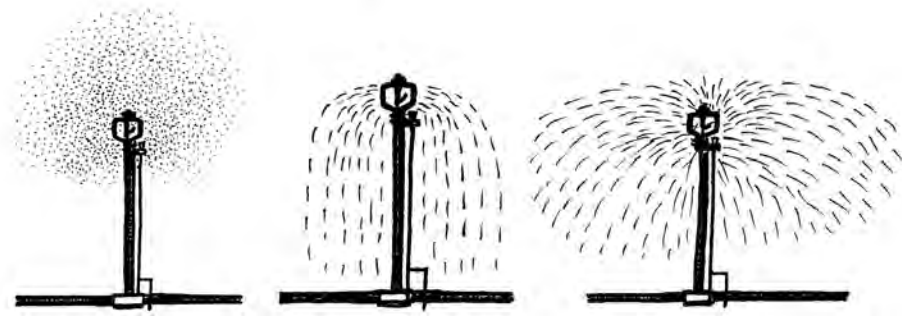

Too high pressure causes misting

Too low pressure affects distribution uniformity

Optimum pressure is ideal condition

- **Water discharge / flow rate** The volume of water collected over a specified period of time. For small flows it is measured as liters per second (lps). Every sprinkler requires a minimum discharge for effective operation which is usually given in the manufacturers' product specifications.

- **Precipitation rate** The average height of the collected water that has fallen on the ground from the sprinklers over a specified period of time, measured as mm per hour. If the precipitation rate is higher than the intake rate of the soil, runoff will occur, particularly in heavy soils and uneven surfaces. Therefore, the precipitation rate is an important factor to consider when selecting the type of sprinkler to use. Generally, small sprinklers have a slower application rate, thereby lowering their ability to cause runoff damage.

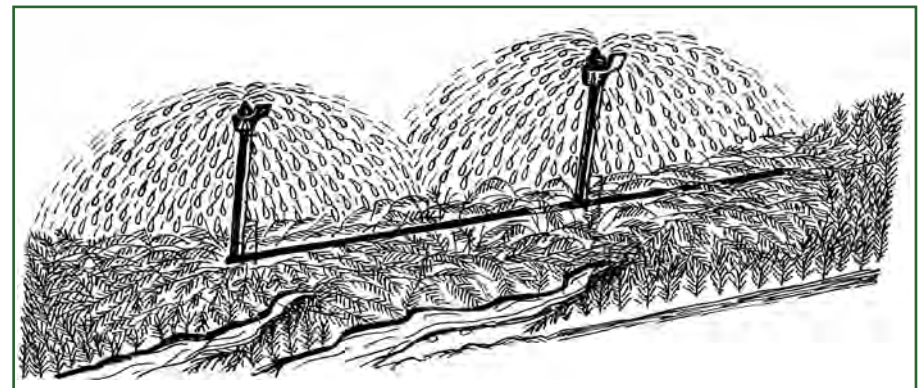

Runoff due to high application rate

### 3. MAIN FEATURES AND APPLICATION OF SPRINKLER SYSTEM

- A complete set of the technology is preassembled for easy use
- It is simple to install, operate and maintain
- It creates light precipitation and more irrigation coverage, making soil erosion nearly negligible
- Land leveling is not required for use
- It is low-cost and durable equipment

Due to these features, sprinkle irrigation works well on rolling land with porous soil. Its optimal use is for irrigation of close-grown crops of low height; it is not convenient to irrigate tall crops with sprinklers. Additionally, application uniformity can be influenced by heavy winds and water pressure. Hence, the sprinkler system should be operated during non-windy periods and water pressure must be regulated with valves

### 4. COMPONENTS OF THE SPRINKLER IRRIGATION SYSTEM

The complete sprinkle irrigation system can be broadly divided into two major components: the water acquisition component and the water distribution component. Subcomponents are listed in the table on page 8.



Components of a sprinkler irrigation system

### Components of a Sprinkle Irrigation System

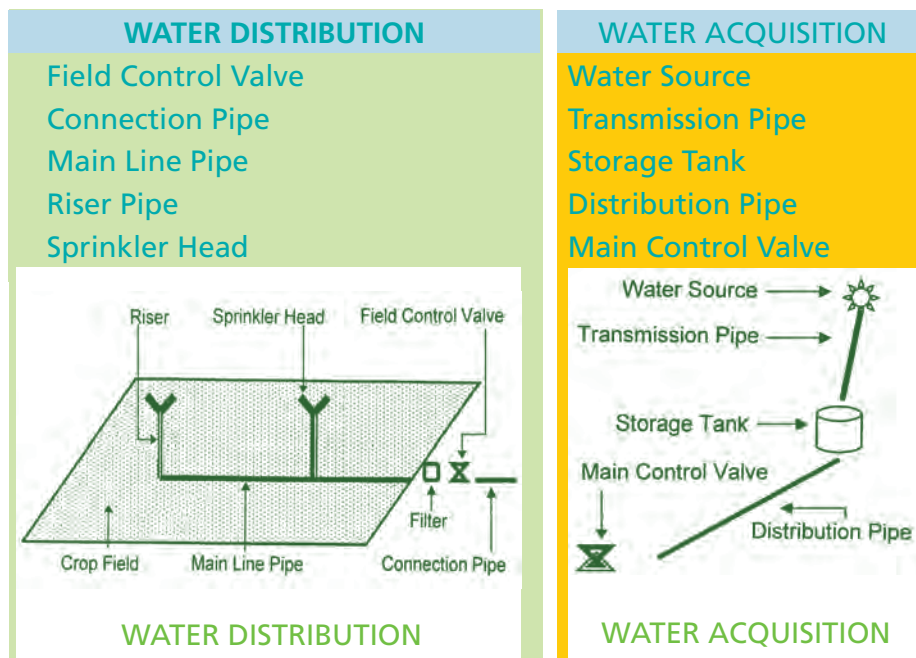

### 5. SIZES AND TECHNICAL PARAMETERS

With the technical support of IDE/Nepal, sprinkler systems are prefabricated in 3 standard designs, two using micro-sprinkler heads and one using either butterfly or arm mini-sprinkler heads. The Small Micro-sprinkler System (SMS) comes with four micro-sprinkler heads while the Large Micro-sprinkler System (LMS) comes with eight micro-sprinkler heads, allowing it to irrigate a larger area. The Mini-sprinkler System (MSS) comes with 2 sprinkler heads that can be chosen from the following types: the circular butterfly sprinkler head, the triangular butterfly sprinkler head, or the arm sprinkler head. The attributes of the three sprinkle system sets are shown in the table on the following page.



Butterfly Mini-Sprinklers

Arm Mini-Sprinklers

Micro Sprinklers

Sprinkler head specifications	SMS	LMS	MSS
Nozzle diameter	1.2	1.2	2.2
Pressure head minimum (m)	8	10	12
Pressure head maximum (m)	15	15	20
Wetting diameter at minimum head (m)	7	7	10
Wetting diameter at maximum head (m)	9	8	12
Discharge at minimum head (lps)	0.10	0.20	0.20
Discharge at maximum head (lps)	0.15	0.28	0.30
Sprinkle set attributes			
Model sprinkler head	SMS	LMS	MSS
No. of sprinkler heads per set	4	8	2
Avg. irrigation coverage with 3 shifts/day (m <sup>2</sup> )	250	500	240
Spacing between sprinklers (m)	4	4	5
Water pressure (m)	8-15	10-15	12-20
Average discharge (lps)	0.12	0.25	0.25
Price of complete set in NRs (2007)*	881	1655	767

\* Price subject to change due to alterations in the price of raw materials and other input costs.

## 6. MATERIAL AND PARTS

The complete set of a preassembled mini- or micro-sprinkler system consists of two subsets: mainline and riser.

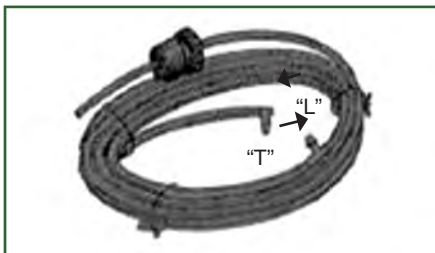

Mainline Subset

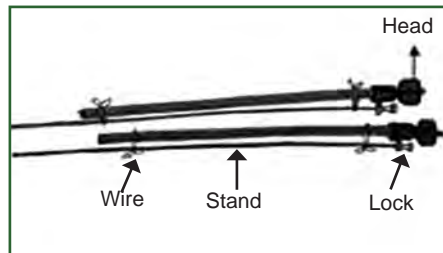

Riser Subset

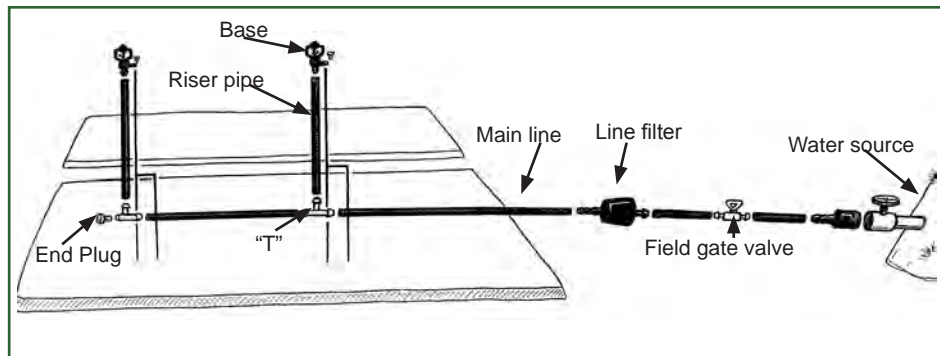

Each subset consists of a number of parts. The quantities of these parts for all system sizes are given in the following table.

### List of sprinkler system parts

Description	SMS	LMS	MSS	Sketch
Field gate valve	1	1	1	
Line filter	1	1	1	
Main line (meters)	14	30	8	
"T"	4	8	2	
Riser pipe	4	8	2	
Base	4	8	2	
Heads	4	8	2	
Stand	4	8	2	
End plug	2	2	2	

## 7. INSTALLATION AND OPERATION PROCESS

### 7.1 WATER CONVEYANCE UP TO THE FIELD

Arrange the water supply of required discharge and pressure up to the irrigation field. Gravity can be used to reach the desired pressure as shown below.

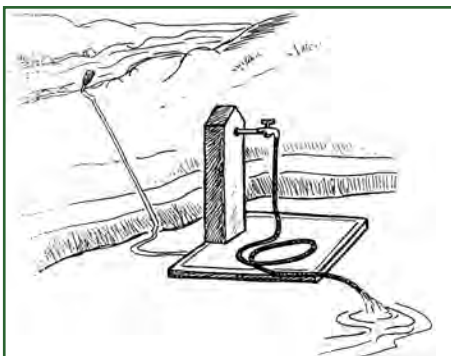

Tap Stand

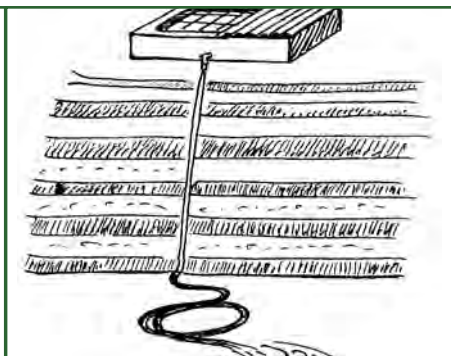

Tank

Water pressure can also be created by electric or diesel pumps as shown below.

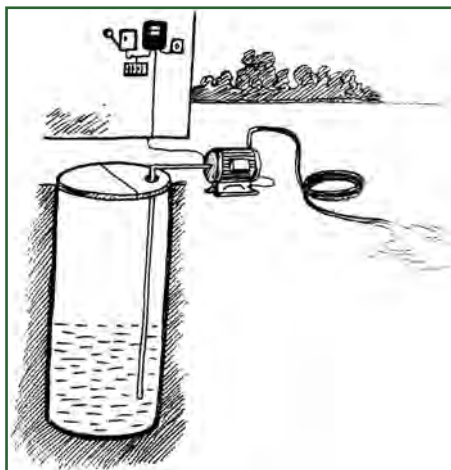

Electric pump

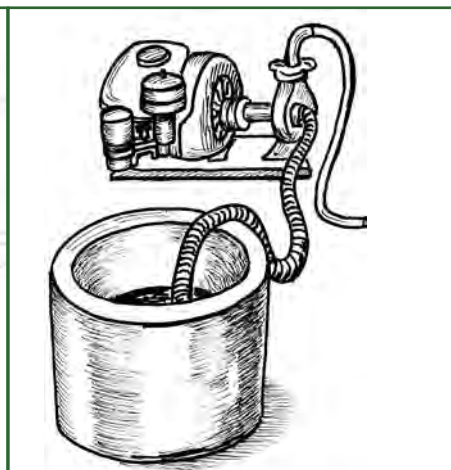

Diesel pumpset

### 7.2 FIXING SPRINKLER SETS AND PIPES ON THE FIELD

Unroll the sprinkle system, fix the riser sets on the field and connect the open end of the mainline with the connection pipe or directly to the water source. The system can be connected to an offtake, tapstand under pressure, or pump outlet.

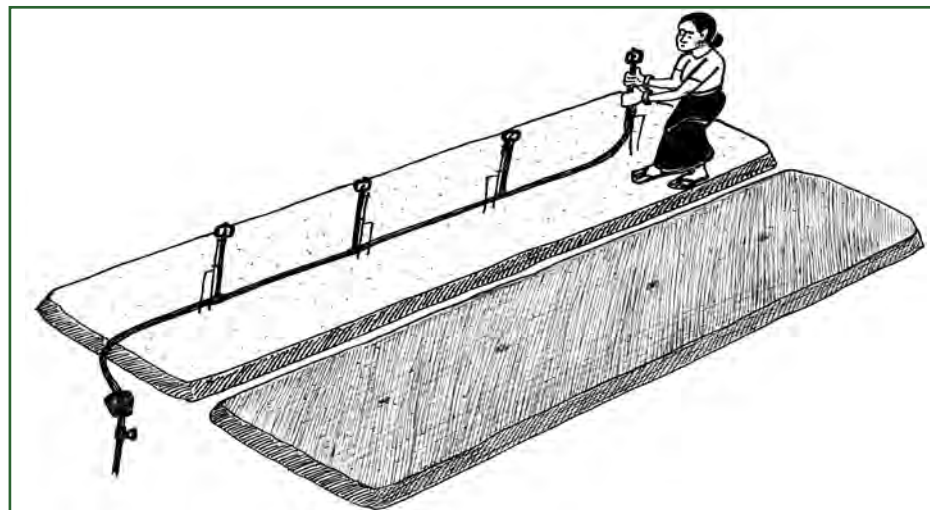

Fixing sprinkler sets on the field

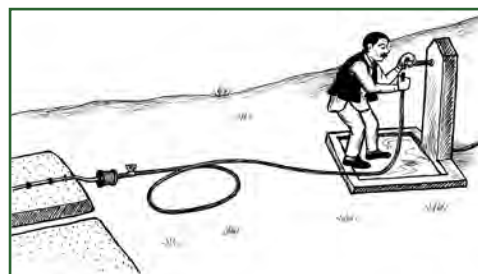

Connecting main line with water source

### 7.3. IRRIGATING THE FIELD

Turn on the water tap and open the gate valve to operate the sprinklers. The time of operation will depend on the crop and climate. Recommended irrigation guidelines for the hills of Nepal are given in the following table.

## Schedule of irrigation

Crop season	Month	Irrigation time (hours)	Irrigation interval
Winter	Oct	1	Alternate day
	Planting: Oct	2	2 day interval
	Harvesting: Jan	2	3 day interval
	Jan	1	2 day interval
Spring	Feb	1	Alternate day
	Planting: Feb	3	3 day interval
	Harvesting: Apr	3	3 day interval

## 7.4 MOVING THE SPRINKLER POSITION

After irrigating the recommended amount on one portion of the field, close the control valve and move all sprinkler heads along with the mainline pipe to the next part of the field. Open the gate valve again to operate the sprinklers.

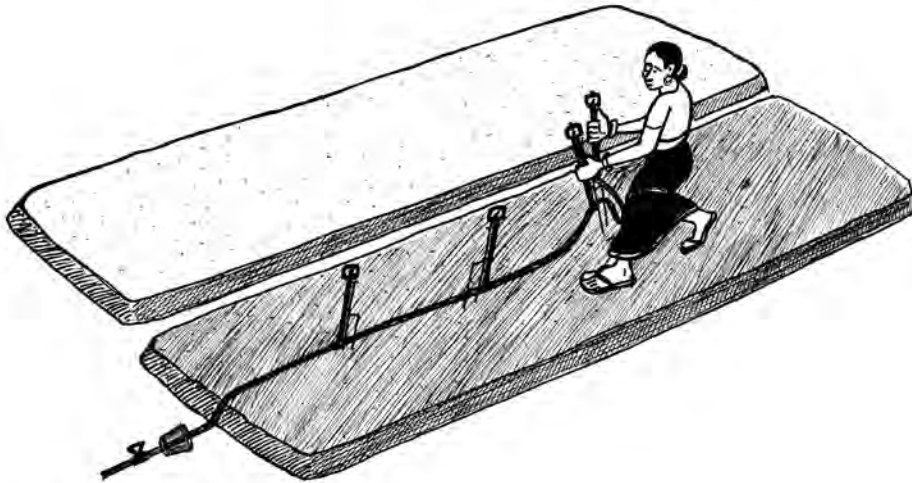

*Moving the sprinklers*

## Some important considerations when irrigating

- **Effect of Wind** Sprinkler water distribution uniformity is greatly influenced by the direction of the wind. Hence, it is recommended to operate the sprinklers during periods of low wind.

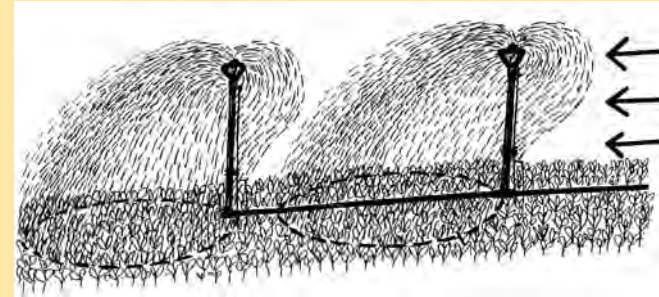

*Effect of wind on water distribution*

- **Optimum Pressure and Discharge** To maintain good water distribution uniformity, the inlet pressure must be maintained at an optimum level. Leakage and breakage of the pipelines can drastically reduce the discharge and pressure, resulting into poor sprinklers performance. Make sure to regularly check for leaks and repair them.

- **Verticality of the Sprinkler Head** If the sprinkler head is at an incline it will create acentric watering application. Thus, sprinkler heads must be kept vertical while operating.

- **Timing of Irrigation** Neither over-irrigation nor under-irrigation are desirable for plant growth or the environment. Irrigating more than the infiltration capacity of the soil will cause run off. On the other hand, too little irrigation will have a negative impact on the growth and productivity of the crops. Hence, it is suggested to maintain irrigation application close to the recommended schedule shown in the table on the previous page.

## 8. MAINTENANCE AND STORAGE

### 8.1 CLEANING OF THE LINE FILTER

The line filter needs to be cleaned once every week to two weeks depending on water quality. Accumulation of impurities inside the filter can cause the sprinklers to malfunction. To clean the filter, unscrew the outer case and rinse the slotted portion with clean water.

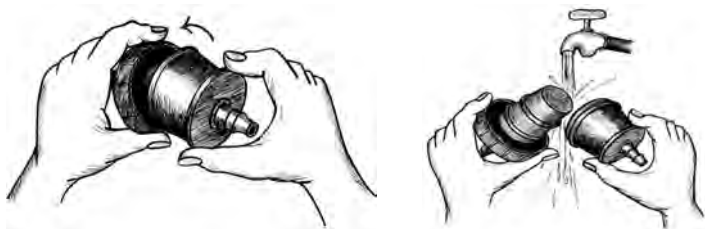

### 8.2 CHECKING THE PIPELINES

It is important to securely connect the pipe and fittings in order to have optimal sprinkler function. Any leaks in the pipeline will cause a drop in pressure and discharge which will result in poor sprinkler head rotation. If leaks are found, check all connections to make sure they are secure. If the leaks persist, repair them with tape.

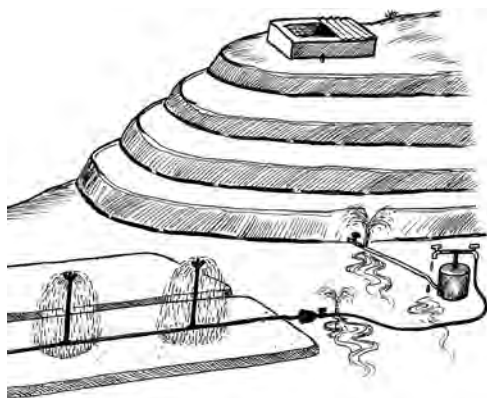

### 8.3 STORAGE

During the rainy season when irrigation is not required, the sprinkler set should be stored in a safe place, preferably indoors to reduce wear and tear.

## 9. WHERE TO PURCHASE THE TECHNOLOGY

In conjunction with partner organizations, IDE is assisting in market promotion and technical services of the sprinkle system technology. Currently, three companies are assembling and distributing the sprinkle systems. These companies distribute the sprinkle systems to local dealers in various regions of Nepal. In order to purchase a sprinkle system, contact one of the companies listed below and they will provide information on the local dealer nearest to you.

#### THAPA MOLD AND DIES (TMD)

Business Type	Manufacturer
Location	Gwarkhu, Lalitpur
Telephone No	01-5203688
Contact person	Mr. Chandra B. Thapa

#### JANASEWA AGRO INPUT CENTER

Business Type	Assembler cum Distributor
Location	Chipledhunga, Pokhara, Kaski
Telephone No	06-1533124
Contact person	Mr. Narayan Gautam

#### SITAL AGROVET TRADING CENTER

Business Type	Assembler cum Distributor
Location	Birendranagar, Surkhet
Telephone No	08-3520778
Contact person	Mr. Dilli R. Pandey

